

TRIGGER LATCHES

DESCRIPTION	For easy, secure, and compressive latching and locking of doors and flaps.
MATERIAL	Housing, handle, and trigger: Die-cast zinc Bolt: Mild steel
SURFACE	Housing, handle, and trigger: Black powder coated / chrome plated Bolt: Zinc plated

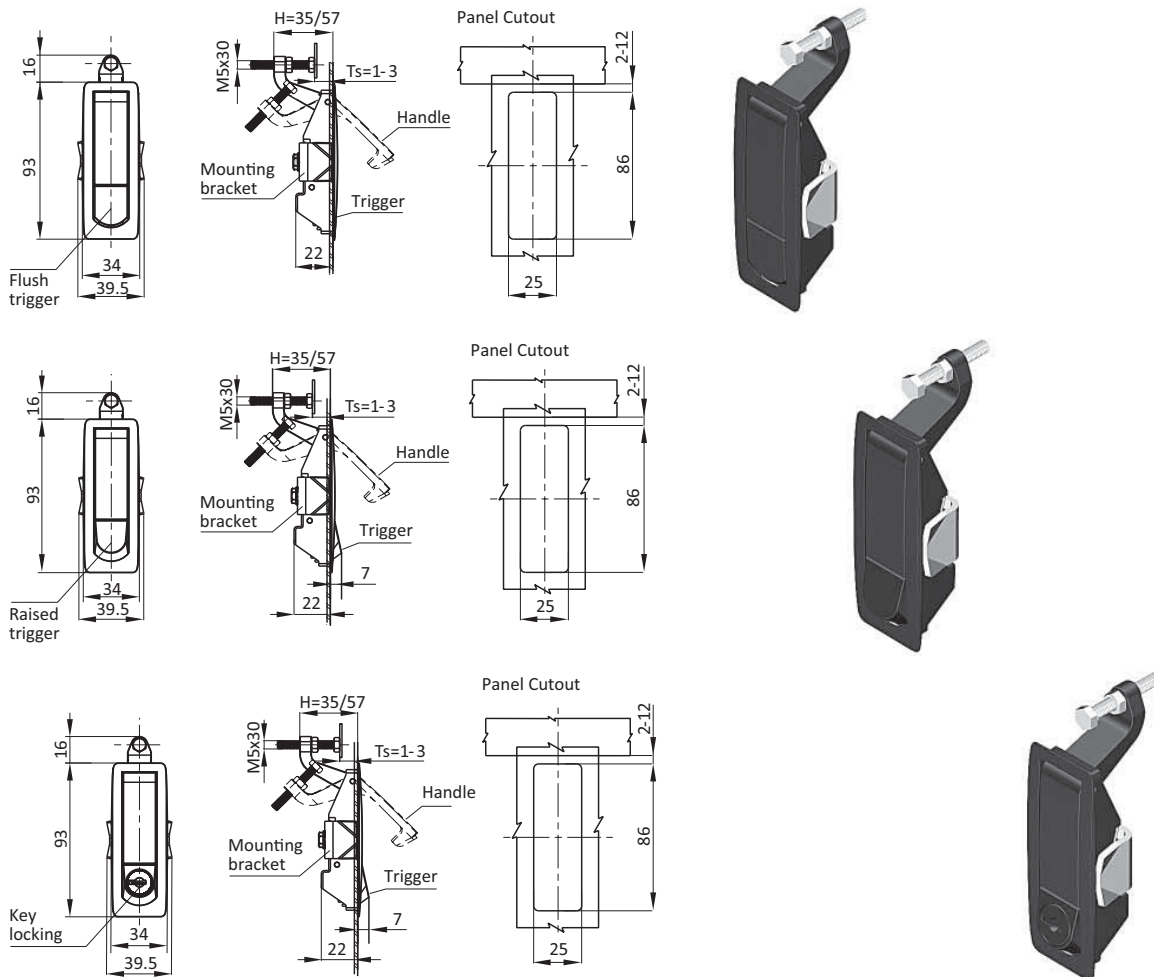

Trigger Latches	Trigger Style	Die-cast Zinc, black powder coated	Die-cast Zinc, chrome plated	NEMA 4 black powder coated
Short arm Grip range 1 - 24 mm	Non-locking raised trigger	TL56	TL60	TL240
	Non-locking flush trigger	TL57	TL61	TL241
	FH751 key locking	TL58	TL62	TL242
	Phillips Drive	TL74	TL76	TL243
	FH751 key locking with shutter	TL59	TL63	TL244
	Hexagon female 4.5mm	TL75	TL77	TL245
Long arm Grip range 23 - 46 mm	Non-locking raised trigger	TL64	TL68	TL246
	Non-locking flush trigger	TL65	TL69	TL247
	FH751 key locking	TL66	TL70	TL248
	Phillips Drive	TL78	TL80	TL249
	FH751 key locking with shutter	TL67	TL71	TL250
	Hexagon female 4.5mm	TL79	TL81	TL251