

HANDLE COMPRESSION LATCHES - LONG SHAFT

DESCRIPTION	For easy, secure, and compressive latching and locking of doors and flaps.
MATERIAL	Handle and Housing: Die cast zinc Shaft: Mild steel
SURFACE	Handle and Housing: Black powder coated Shaft: Zinc plated

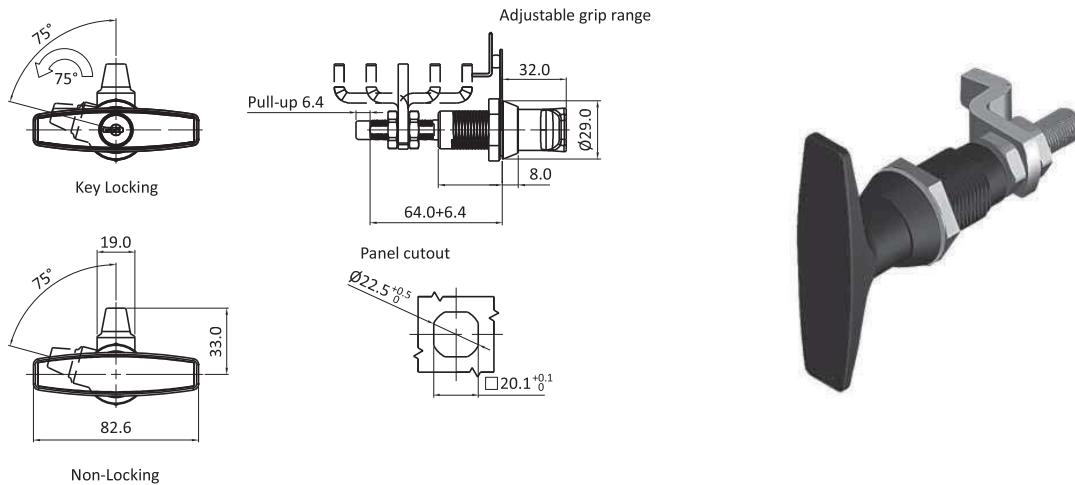

WINGKNOB COMPRESSION LATCHES

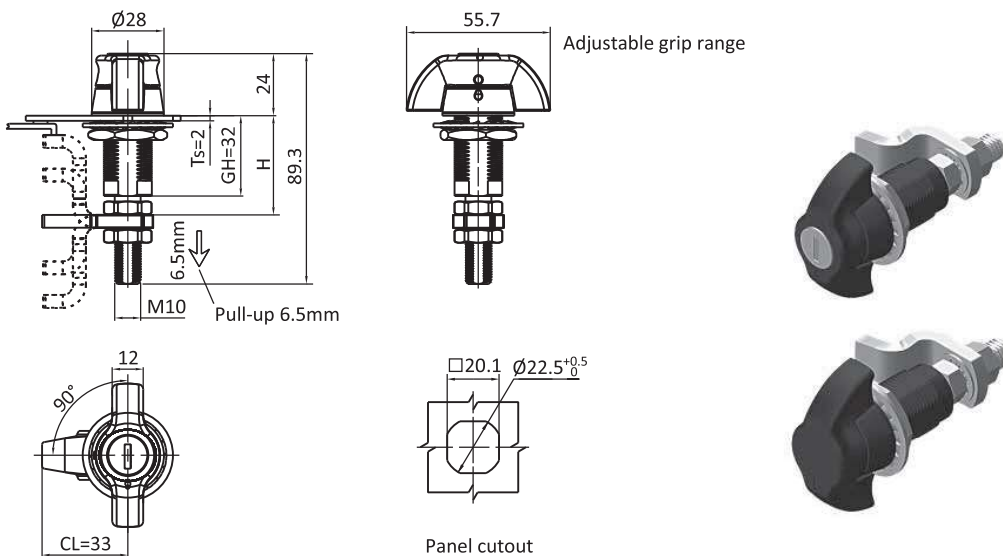

Cam Orientation	Grip Range		T-HANDLE		WING KNOB	
	Minimum	Maximum	FH751 Key Locking	Non-locking	FH333 Key locking	Non-locking
Reversed Cam	11.4	27.2	HCLRC144	HCLRC147	HCLRC099	HCLRC102
	25.4	41.1	HCLRC145	HCLRC148	HCLRC100	HCLRC103
Straight Cam	38.9	54.6	HCLSC146	HCLSC149	HCLSC101	HCLSC104
Offset Cam	52.6	68.3	HCLOC145	HCLOC148	HCLOC100	HCLOC103
	66.3	76.2	HCLOC144	HCLOC147	HCLOC099	HCLOC102