

LARGE COMPRESSION LATCHES

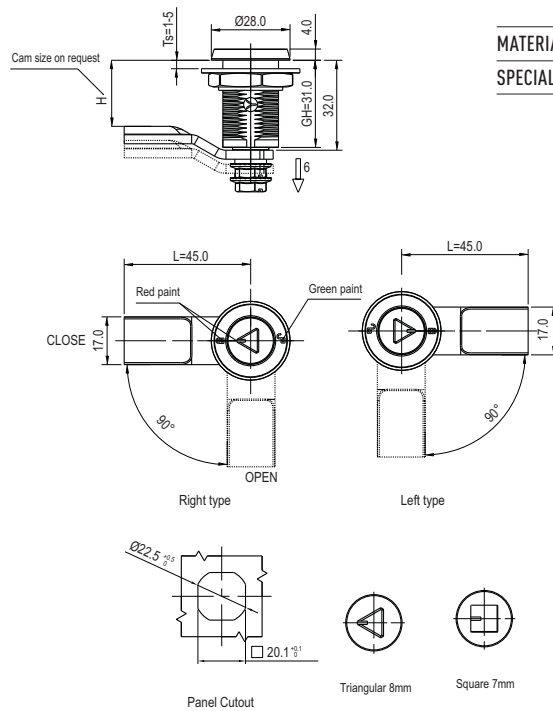

| | |
|-------------|--|
| DESCRIPTION | For easy, secure, and compressive latching and locking of doors and flaps. |
| MATERIAL | 316 SS |
| SPECIALS | Right and Left |



| Large Compression Latches | Cylinder Style | Left | Right |
|---------------------------|----------------|--------------|--------------|
| | Triangular 8mm | LCL60 | LCL61 |
| | Square 7mm | LCL58 | LCL59 |

T-HANDLE COMPRESSION LATCHES - SHORT SHAFT

| | |
|-------------|--|
| DESCRIPTION | For easy, secure, and compressive latching and locking of doors and flaps. |
| MATERIAL | Handle and Housing: Die cast zinc Shaft: Mild steel |
| SURFACE | Handle and Housing: Black powder coated Shaft: Zinc plated |

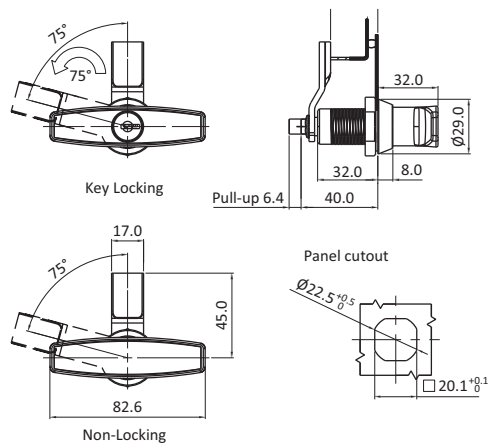

| T-Handle Compression Latches - Short Shaft | FH751 Key locking | Non-Locking |
|--|-------------------|---------------|
| | LCL142 | LCL143 |