

**SPRING STYLE QUARTER TURN LOCKS**

DESCRIPTION	For easy and secure latching and locking of doors and flaps. Wide range of cams and accessories.
MATERIAL	316 SS

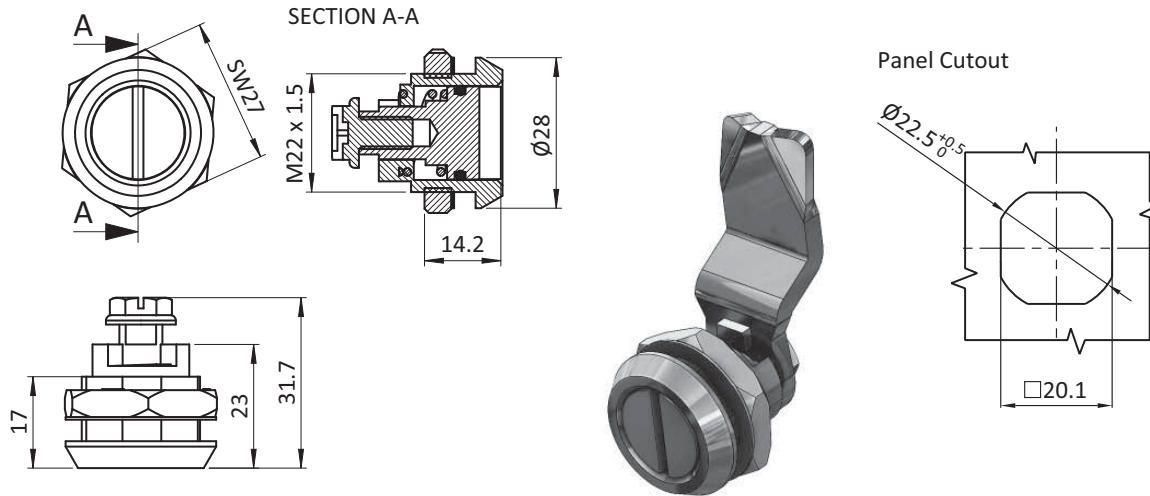

Spring Style Quarter Turn Locks

2 x 4 slot

Stainless Steel

**SSQTL27E501**
**HYGIENIC QUARTER TURN LOCKS**

DESCRIPTION	For easy and secure latching and locking of doors and flaps. Wide range of cams and accessories.
MATERIAL	316 SS

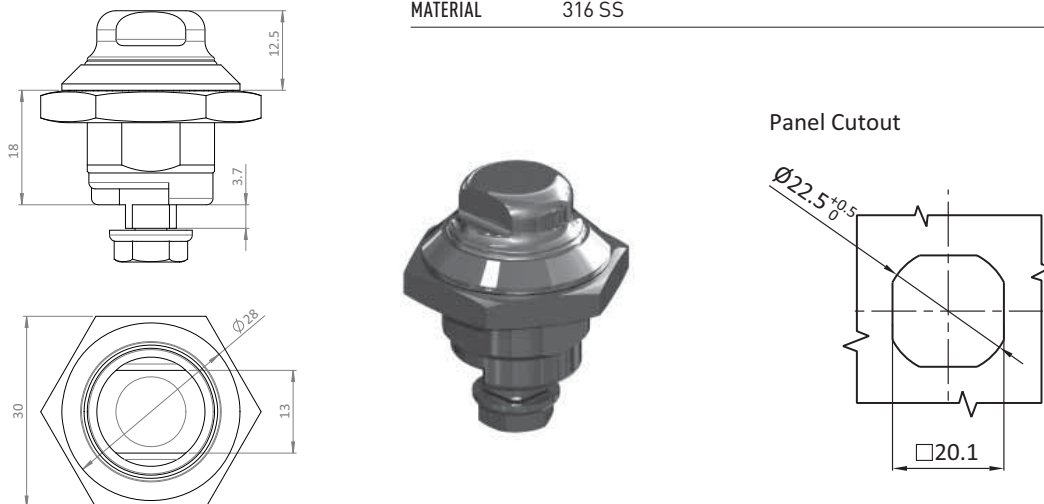

SW13 INSERT

Stainless Steel

**SSQTL2150E**