

**EMERGENCY OPENER FOR SLAM LATCHES**

DESCRIPTION	Inside emergency release for slam latches PROe, PRO and Compact; with or without safety catch
MATERIAL	Base part: Nylon PA, glass Fiber reinforced Push button: Nylon PA, glass Fiber reinforced Unlocking plate: Steel
SURFACE	Unlocking plate: Zinc plated
COLOR	Base part: Black Push button: Red ≈RAL 3020
FASTENING	From the front, using two socket head screws DIN 912 M6 x 20, Hardware included

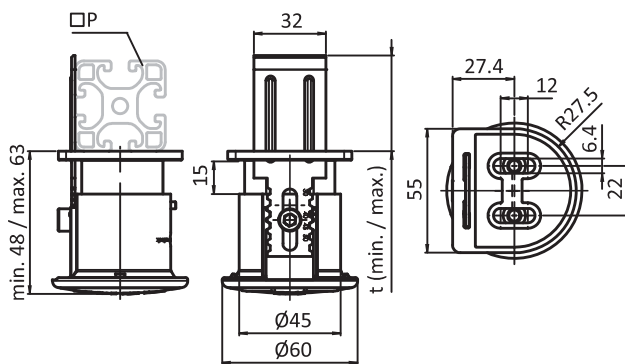

Emergency Opener for Slam Latch	t (min.) [mm]	t (max.) [mm]	P [mm]	Weight [g]	Part #
Without safety catch	30	50	30-50	110.8	<b>EOSL409</b>
	60	80	60-80	115.4	<b>EOSL409S03</b>
With safety catch	30	50	30-50	110.8	<b>EOSL409S02</b>