

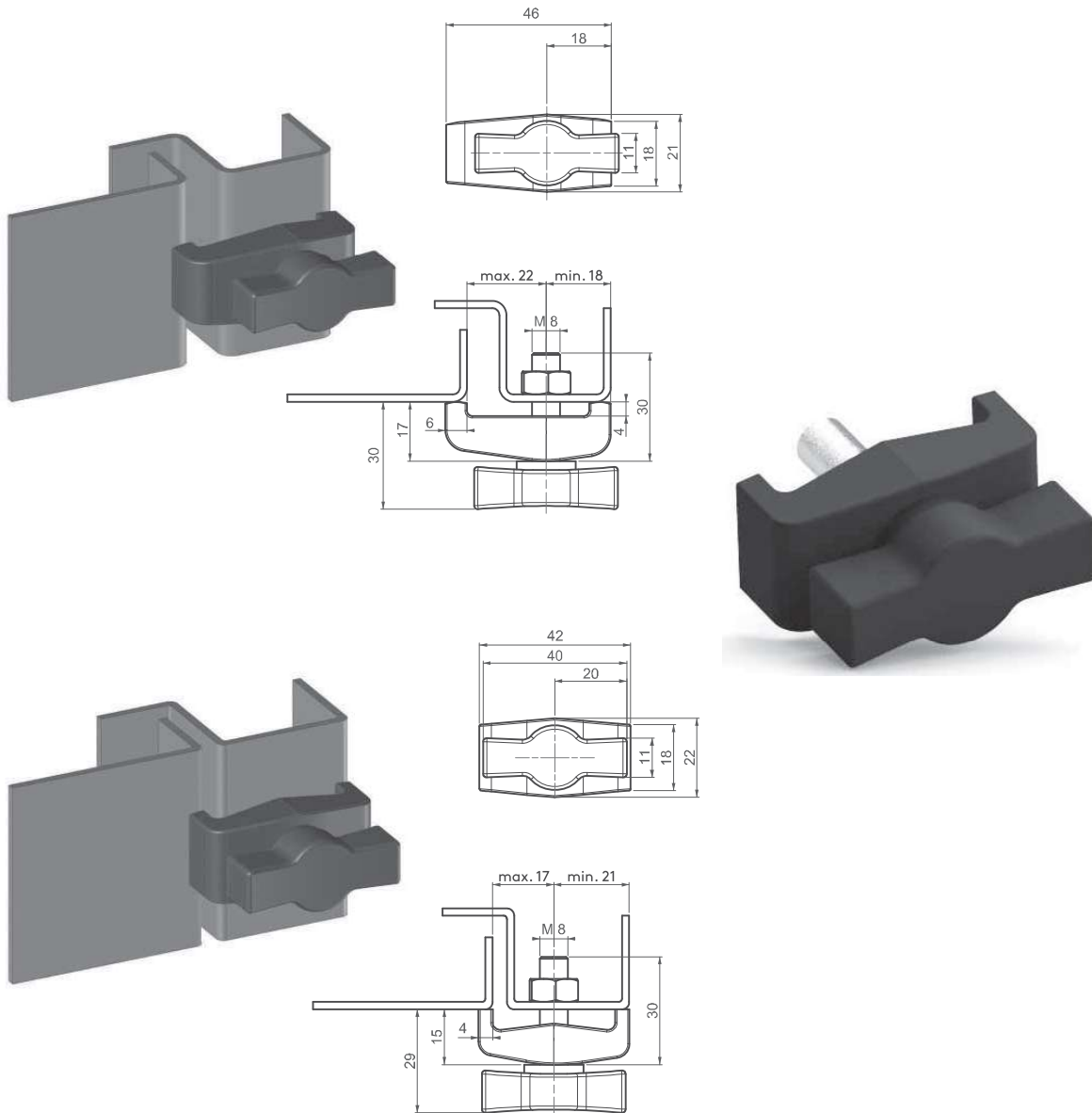

### HVAC BRIDGE CLAMP SYSTEM

DESCRIPTION	HVAC Bridge Clamp System
MATERIAL	Housing: PA6 GF30 Knob: PA6 GF30 Screw: Steel Zinc Plated
COLOR	Black



Clamp Range

22.0 x 18.0 Max

17.0 x 21.0 Max

Part #

HBCS336

HBCS337