

FRICTION HINGES

DESCRIPTION	To hinge panels
MATERIAL	PA 6 Pin Steel
SURFACE	Black
SPECIALS	Life: Within 20 percent of stated torque after 25,000 cycles

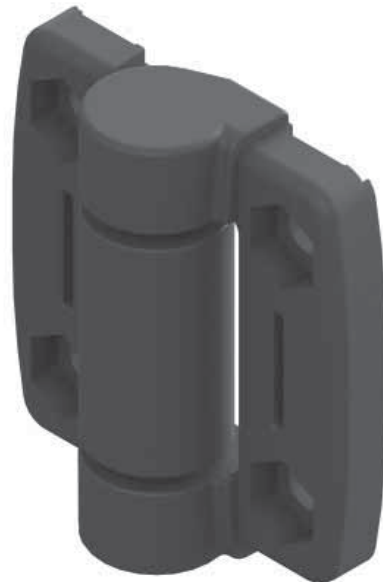
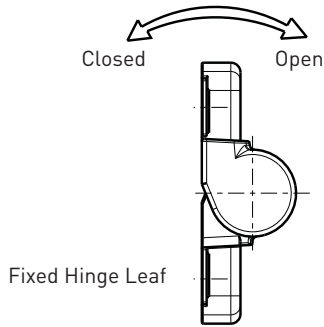
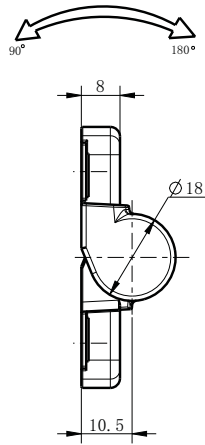
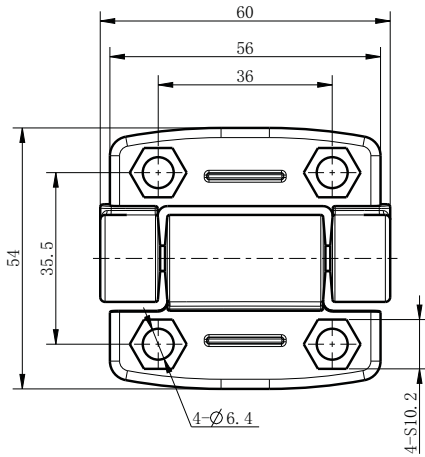

Cover Caps sold separately
 Part # 095SA30
 Quantity 2 required

Screw-On Torque Hinge

	Torque to open Nm(INLB)	Torque to close Nm(INLB)	Black Powder Coat
Reverse	2.3 (20.4)	0.3 (2.7)	FHRB3030A00
Forward	0.3 (2.7)	2.3 (20.4)	FHFB3030A00