

COMBINATION LOCK SWING HANDLE - CAM STYLE

DESCRIPTION	For easy and secure latching and locking of doors and flaps. Wide range of cams and accessories.
MATERIAL	Body: PA, glass fiber reinforced Handle: PA, glass fiber reinforced Hardware: Mild steel
COLOR	Black
SPECIALS	Right and left Large Size Unique key version on request FH751 key code on request

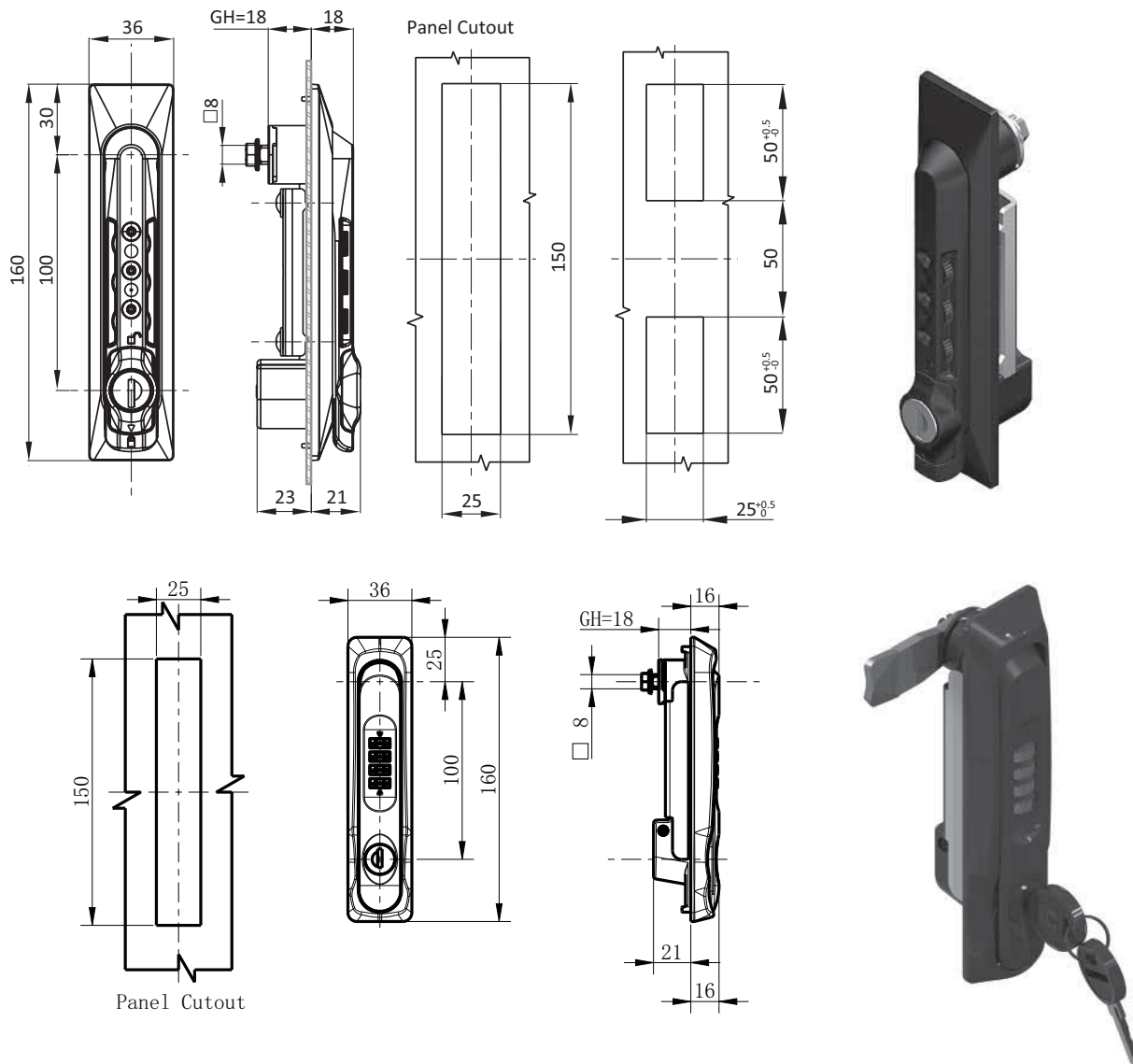

Combination Lock Swing Handle - Cam Control	Keyed	Number of Pins	Part #
	FH333	Three Pin	CLSHCS046
	FH333	Four Pin	CLSHCS180
	Custom Key Code Available	Four Pin	CLSHCS180-XXXX

TO SELECT CAM - SEE (SQTC - SERIES)