

CYLINDER LOCK SWING HANDLE - CAM CONTROL

DESCRIPTION	For easy and secure latching and locking of doors and flaps. Wide range of cams and accessories.
MATERIAL	Body: Die-cast zinc / PA, glass fiber reinforced Handle and shaft: Die-cast zinc Hardware: Mild steel
SURFACE	Black powder coated Hardware: Zinc plated
SPECIALS	Right and left Large Size Unique key version on request FH751 key code on request Padlock version on request

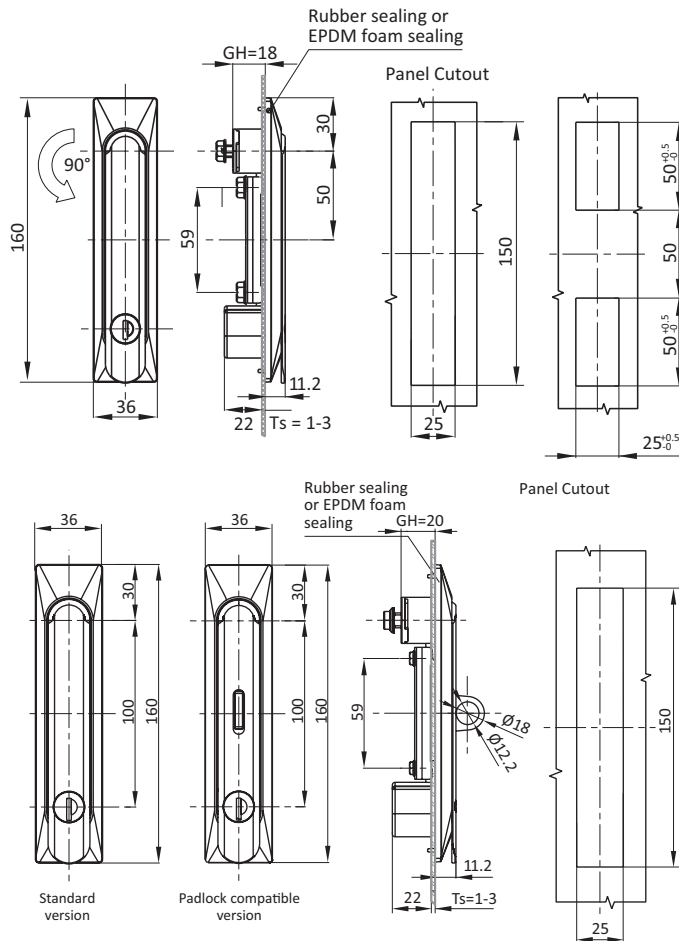

Style A



Style B



Profile Cylinder Swing Handle - Cam Control	Style	Insert	Padlock Hasp	GH (mm)	Part #
Die cast handle / PA housing	A	With FH333 key insert	N	18	CLSHCC43
Die cast handle / PA housing	A	With FH333 key insert	Y	18	CLSHCC43S03
Die cast handle / PA housing	B	With FH333 key insert	N	20	CLSHCC44
Die cast handle / PA housing	B	With FH333 key insert	Y	20	CLSHCC44S02
Die cast handle and housing	B	With FH333 key insert	N	20	CLSHCC45
Die cast handle and housing	B	With FH333 key insert	Y	20	CLSHCC45S05
Die cast handle and housing	B	8mm Square drive	N	18	CLSHCC45S01
Die cast handle and housing	B	With no key insert	Y	20	CLSHCC61
Die cast handle and housing	B	5/16 Female, 3mm Pin	Y	20	CLSHCC62S01