

**SLAM/SLIDE LATCHES COMPACT**

|                    |   |
|--------------------|---|
| <b>DESCRIPTION</b> | For easy and secure latching and locking of doors and flaps, no mechanical preparation needed for the assembly; safe against disassembling in the locked position |
| <b>MATERIAL</b>    | Die-cast aluminum   |
| <b>SURFACE</b>     | Black powder coated / aluminum color powder coated  |
| <b>FASTENING</b>   | From the front, using M6 socket head or pan head screws   |

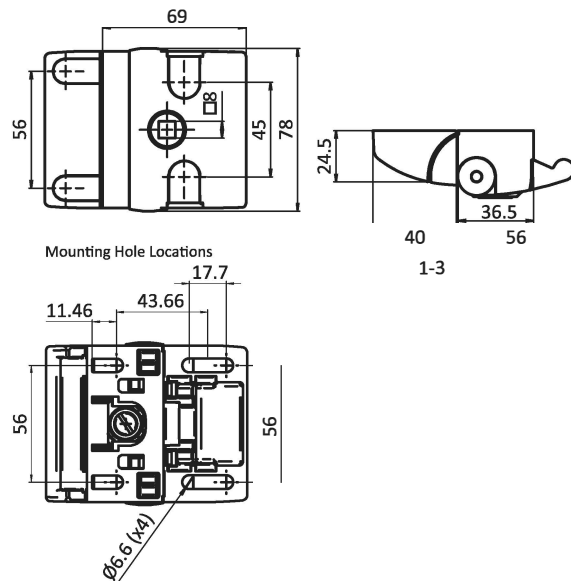

| Slam Latch       | Lock                         | Weight [g]        | Part #                 |
|------------------|------------------------------|-------------------|------------------------|
| SLAM LATCH       | Black powder coated          | Keyed FH333       | 235.5 <b>SLC408</b>    |
|                  |                              | Keyed Differently | 235.5 <b>SLC411</b>    |
|                  |                              | Non Locking       | 204.0 <b>SLC410</b>    |
|                  | Aluminum color powder coated | Square Insert     | 220.0 <b>SLC431</b>    |
|                  |                              | Double Bit Insert | 220.0 <b>SLC432</b>    |
|                  |                              | Keyed FH333       | 235.5 <b>SLC408S01</b> |
| SLIDE DOOR LATCH | Black powder coated          | Keyed Differently | 235.5 <b>SLC411S01</b> |
|                  |                              | Non Locking       | 204.0 <b>SLC410S01</b> |
|                  |                              | Keyed FH333       | 246.0 <b>SLC415</b>    |
|                  |                              | Keyed Differently | 246.0 <b>SLC416</b>    |
|                  |                              | Non-Locking       | 216.0 <b>SLC417</b>    |