

20-02 SERIES

20-02-10

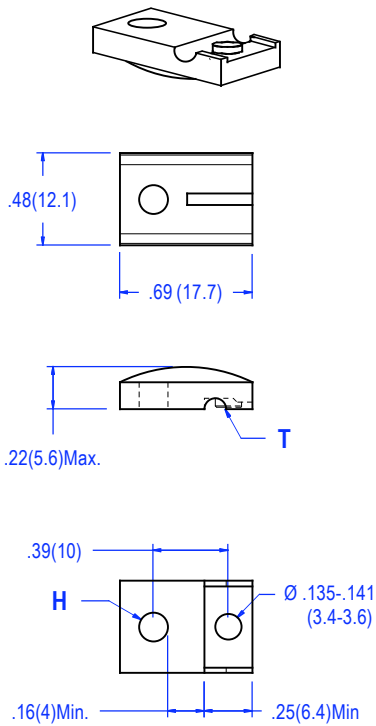

20-02-20

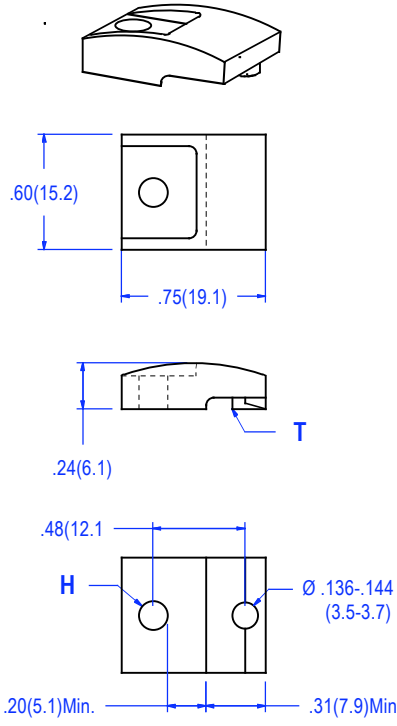

20-02-30

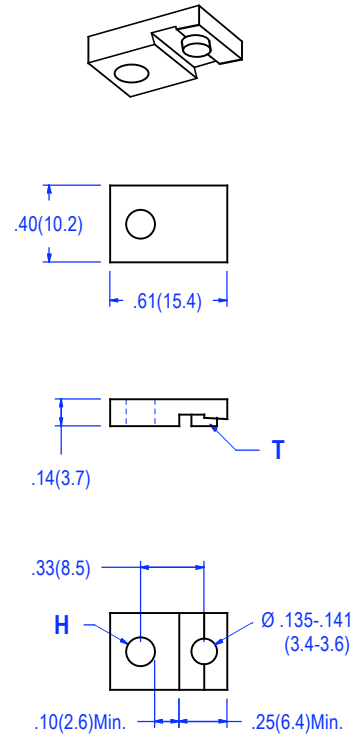

ITEM NO	TRANSISTOR CASE TYPE	MOUNTING Screw size H	TRANSISTOR TAB THICKNESS T	PACKAGING
20-02-10	TO-220V-18	# 6 (M3.5)	.04 -.06 (1-1.5)	1000 / BAG
20-02-20	TO-218			
20-02-30	TO-220-18			

MATERIAL	NYLON 66 GLASS FILLED
GLASS CONTENT	10%
UL RATING	94V-0
UL FILE NO.	E41938
COLOR	BLACK
ASTM	D4066
RoHS COMPLIANCE	YES
TEMPERATURE RANGE (REF.)	-40 to 239°F (-40 to 115°C)
MR NUMBER	28

No	Revision	Date	Init	DRAWN	FL	Date	5-18-12.	Title	TRANSISTOR INSULATORS	Issue
				CUSTOMER'S OK				File No.	2002SERIES	O
				VERIFIED						
				REVIEWED						
									ALL ELECTRONICS HARDWARE, INC. 2642 CORPORATE PARKWAY ALGONQUIN, IL. 60102 1-800-778-7234	5-18-12