

**14-03 SERIES**

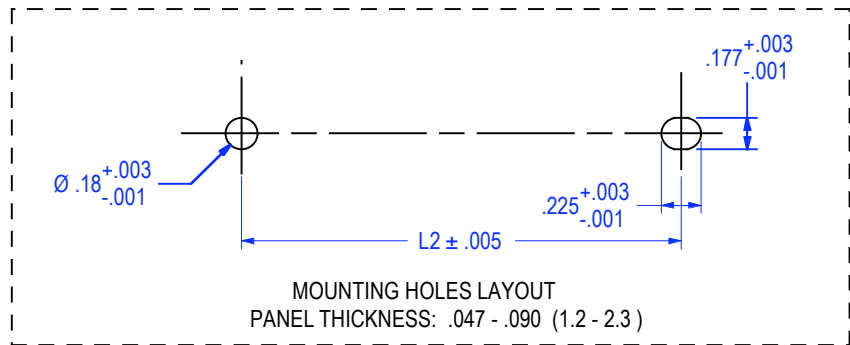
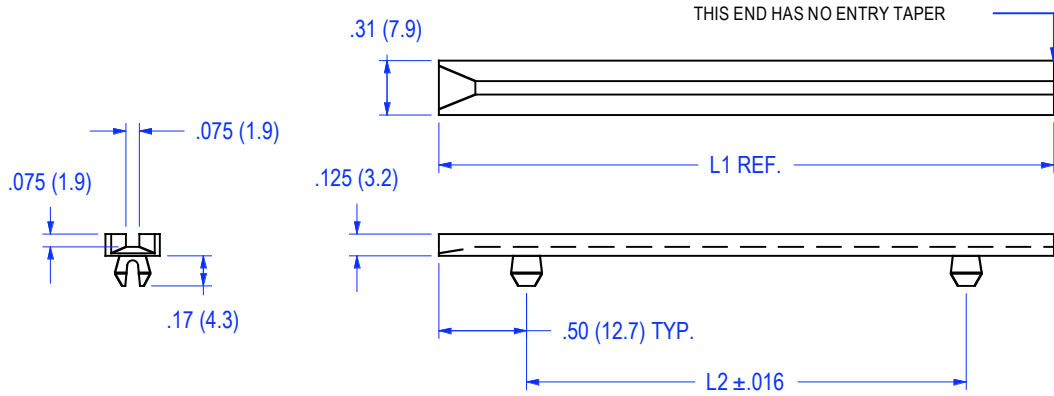

MATERIAL	NYLON 66
UL RATING	94V-2
UL FILE NO.	E70062
COLOR	NATURAL
ASTM	D 4066, PA111
RoHS COMPLIANCE	YES
TEMPERATURE RANGE (REF.)	-40 to 185°F (-40 to 85°C)
MR NUMBER	01

ITEM NO	L1 REFERENCE		L2	
	IN.	mm	+/- .016	(0.41)
UL94-V2			IN.	mm
14-03-250	2.5	(63.5)	1.5	(38.1)
14-03-300	3.0	(76.2)	2.0	(50.8)
14-03-350	3.5	(88.9)	2.5	(63.5)
14-03-400	4.0	(101.6)	3.0	(76.2)
14-03-450	4.5	(114.3)	3.5	(88.9)
14-03-500	5.0	(127)	4.0	(101.6)
14-03-550	5.5	(139.7)	4.5	(114.3)
14-03-600	6.0	(152.4)	5.0	(127)
14-03-650	6.5	(165.1)	5.5	(139.7)
14-03-700	7.0	(177.8)	6.0	(152.4)
14-03-750	7.5	(190.5)	6.5	(165.1)
14-03-800	8.0	(203.2)	7.0	(177.8)

V-0 RATED NYLON AVAILABLE ON REQUEST  
TO ORDER ADD SUFFIX "X" TO PART NUMBER.

PACKAGING: 500/BAG

				Name	Date	Title	
Drawn By				FL	07-07-03		CARD GUIDES, 14 -03 SERIES
Checked By							
Tolerance, unless noted				.xx = .010 .xxx = .005			
G	Added material box	06/27/08	FL	ALL ELECTRONICS HARDWARE, INC. 2642 CORPORATE PARKWAY ALGONQUIN, ILLINOIS 60102 1 800 778 7234.		Drawing Number	
F	.L1 TOLERANCE	10/22/04	gfl			1403G	Issue G
E	Corrected slot dimension	08/23/04	gfl			1403CAT	
No	Revision	Date	By			FileNumber	