

12-09 SERIES

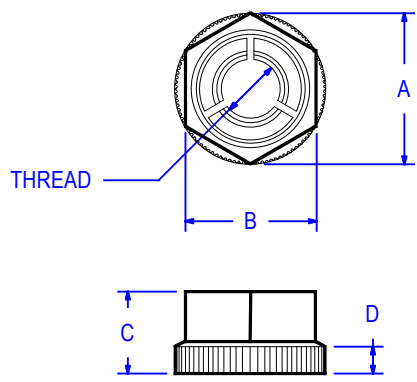

ITEM NO.	THREAD	A		B		C		D	
		Inches	mm	Inches	mm	Inches	mm	Inches	mm
12-09-30	M3	.32	8.2	.28	7	.15	4	.07	1.8
12-09-40	M4	.37	9.4	.32	8	.19	4.7	.07	1.8
12-09-50	M5	.46	11.7	.394	10	.23	5.8	.07	1.8
12-09-60	M6	.60	15.2	.51	13	.26	7	.07	1.8

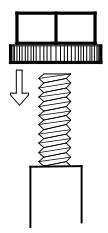

To install: push nut down the length of the threaded stud to the desired position.
Turn nut 180° to lock.
To remove : unscrew with a wrench.

PACKAGING : 1000 PCS. PER BAG

MATERIAL	NYLON 66
UL RATING	94V-2
UL FILE NO.	E41938
COLOR	BLACK
ASTM	D 4066, PA111
RoHS COMPLIANCE	YES
TEMPERATURE RANGE (REF.)	-40 to 185°F (-40 to 85°C)
MR NUMBER	12

				BY	DATE	Title		
				CUSTOMER		PUSH-NUT, QUICK FASTENING.		
				VERIFIED				
				REVIEWED				
				DRAWN	FL 6-2-14			
				DIMS. Inches (mm) Tolerance (unless noted) .xx = ±.010 .xxx = .005			Part No.	Issue
							SEE TABLE	A
				ALL ELECTRONICS HARDWARE INC. 2642 CORPORATE PARKWAY ALGONQUIN, ILLINOIS . 60102 1-800-778-7234			Drwg. type	01-27-16
							CATALOG	
							File No.	12-09series
A	Added item number 12-09-60 and operation note		1-27-16	FL				
No	Revision		Date	Init.				