

09-17series

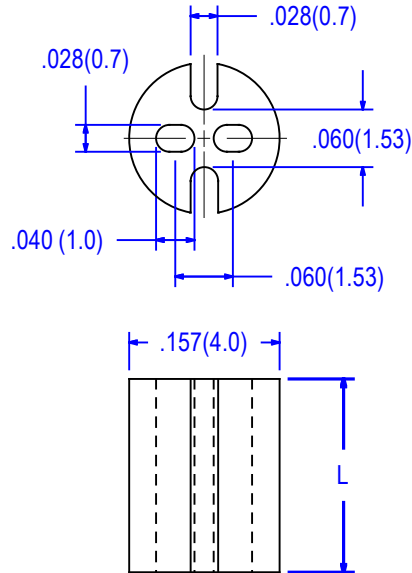

METRIC SIZES

ITEM NO.	L mm. ± 0.4
09-17-50M	5
09-17-60M	6
09-17-70M	7
09-17-85M	8.5
09-17-90M	9
09-17-100M	10
09-17-120M	12
09-17-180M	18
09-17-200M	20
09-17-260M	26
09-17-265M	26.5
09-17-290M	29
09-17-300M.	30

IMPERIAL SIZES

ITEM NO.	L	
	In. ±.015	mm. ± 0.4
09-17-30	.187	4.8
09-17-40	.250	6.4
09-17-60	.375	9.5
09-17-80	.500	12.7
09-17-100	.625	15.9
09-17-120	.750	19.1
09-17-140	.875	22.2

PACKAGING: 1000 PER BAG

MATERIAL.	PVC, RIGID
COLOR	BLACK
UL RATING	94V-O
UL FILE NO.	E41877
RoHS COMPLIANCE	YES
TEMPERATURE RANGE (REF.)	32 to 120°F (0 to 50°C)
MR NUMBER	50

					BY	DATE	Title SPACER For "T1"series LED	
							Part No. 09-17 series	Issue O
					FL	8-16-19	Drwg. type CAT	8-16-19
					DIMENSIONS Inches (mm) Tolerance ±.012 (±0.3) unless noted		File No. 09-17series	
					ALL ELECTRONICS HARDWARE INC. 2642 Corporate Parkway Algonquin, IL. 60102 1-800-778-7234			
No	Revision	Date	Init.					