

04-18-40

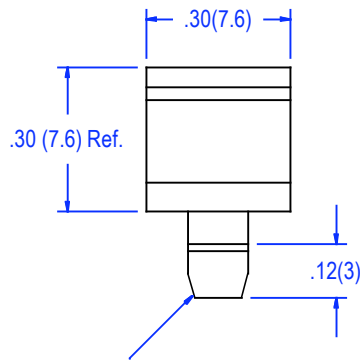
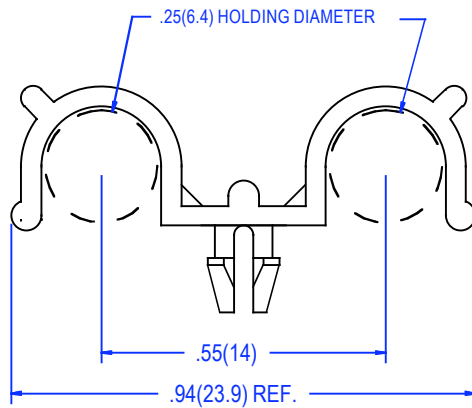

MOUNTING HOLE DIA. = .125±.003 (3.18±0.05)
 PANEL THICKNESS : .062 (1.5)

PACKAGING : 1000 PER BAG

UL 94V-0 MATERIAL AVAILABLE UPON REQUEST
 TO ORDER ADD SUFFIX "X" TO ITEM NUMBER

MATERIAL	NYLON 66
UL RATING	94V-2
UL FILE NO.	E41938
COLOR	NATURAL
ASTM	D 4066, PA111
RoHS COMPLIANCE	YES
TEMPERATURE RANGE (REF.)	-40 to 185°F (-40 to 85°C)
MR NUMBER	12

					BY	DATE	Title DUAL CLIP WIRE HARNESS	
				CUSTOMER APPROVAL				
				VERIFIED				
				REVIEWED	FL	.	Part No.	Issue
				DRAWN	FL	-2-17-13	04-18-40.	0
				DIMENSIONS Inches (mm) Tolerance .xx = ± .010 .xxx = .005				
				ALL ELECTRONICS HARDWARE INC. 2642 Corporate Parkway Algonquin, IL. 60102 1-800-778-7234			Drwg. type	02-17-13
No	Revision	Date	Init.				File No.	041840