

04-08-218
04-08-318.

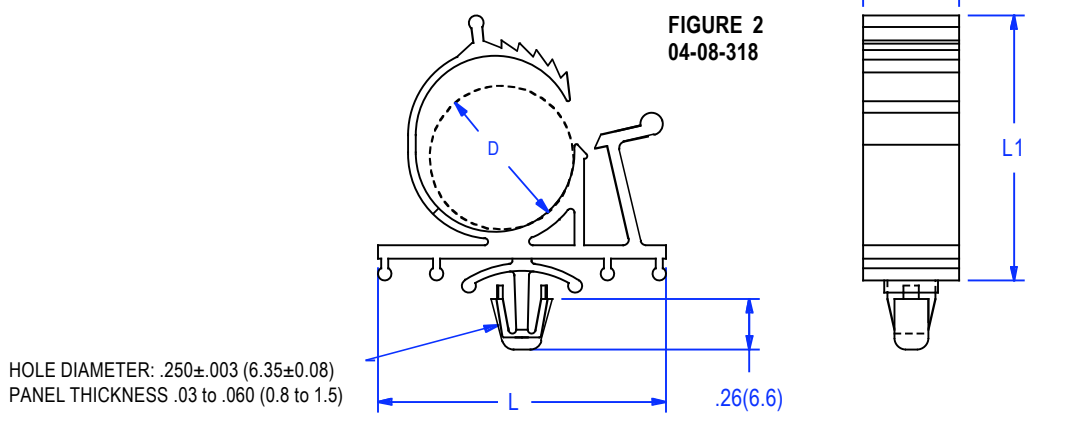
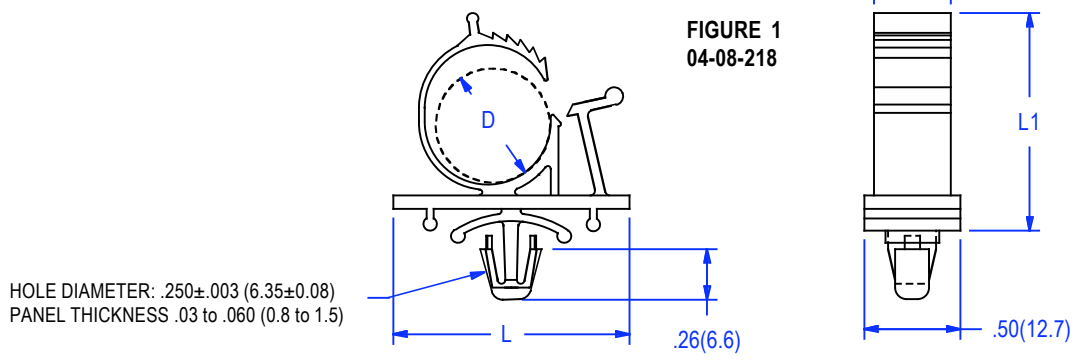

ITEM NO.	D (Ref.) HOLDING Ø RANGE		L		L1		W		FIG. NO.
	Inches	mm	$\pm .015$ Inches	± 0.4 mm	REFERENCE Inches	mm	$\pm .015$ Inches	± 0.4 mm	
04-08-218	.47 - .56	11.9 - 14.3	1.23	31.24	1.10	28	.40	10.16	1
04-08-318	.58 - .75	14.7-19.1	1.50	38.1	1.38	34.5	.50	12.7	2

PACKAGING : 100 PCS. PER BAG

UL94V-0 NYLON AVAILABLE ON REQUEST.
TO ORDER ADD SUFFIX "X" TO ITEM NUMBER.

MATERIAL	NYLON 66
UL RATING	94V-2
UL FILE NO.	E41938
COLOR	NATURAL
ASTM	D 4066, PA111
RoHS COMPLIANCE	YES
TEMPERATURE RANGE (REF.)	-40 to 185°F (-40 to 85°C)
MR NUMBER	12

						BY	DATE	Title	CABLE CLIP. variable diameter. PLUG- IN TYPE.	
						VERIFIED				
						REVIEWED	FL	02-18-13	Part No.	Issue
						DRAWN	FL	10-5-12	SEE DWGS.	A
						DIMENSIONS Inches (mm) Tolerance: as shown				
A	Added part # 04-08-218 and table.			2-18-13	FL	ALL ELECTRONICS HARDWARE INC. 2642 Corporate Parkway Algonquin, IL. 60102 1-800-778-7234			Drwg. type CATALOG	02/18/13
No	Revision			Date	Init.	File No. 0408218&318				