

03-79-138  
03-80-45.

03-79-138

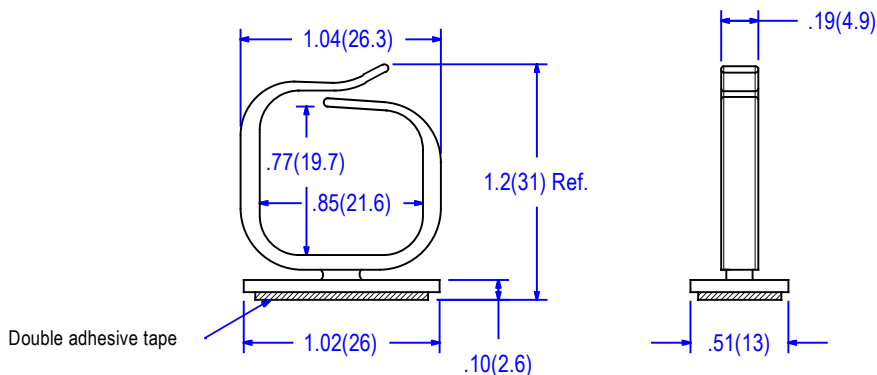

03-80-45

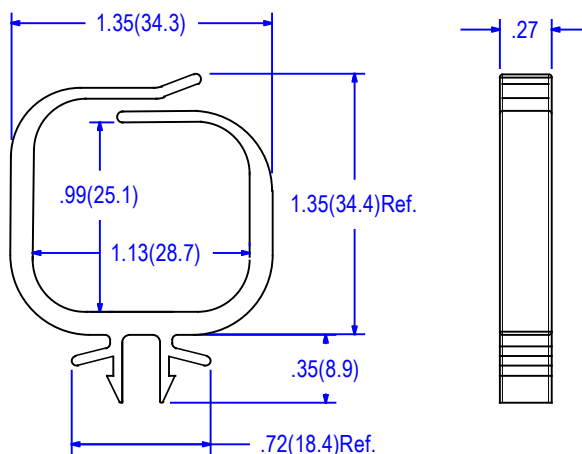

MOUNTING HOLE = .307±.003 ( 7.8±0.08) SQUARE  
PANEL THICKNESS RANGE = .031-.078 ( 0.8 - 2 )

Notes:

1. All edges are rounded and smooth.
2. UL 94V-O material available on request  
To order add suffix "X" to Item number.
3. Packaging: 500 per bag.

ADHESIVE	RUBBER
CARRIER	POLYETHYLENE FOAM
THICKNESS	.040 (1 mm)
COLOR	WHITE
UL FILE NO.	NA
RoHS COMPLIANCE	YES
SERVICE TEMP.	14 to 113°F (-10 to 45°C)
MR NUMBER	59

MATERIAL	NYLON 66
UL RATING	94V-2
UL FILE NO.	E41938
COLOR	NATURAL
RoHS COMPLIANCE	YES
SERVICE RANGE	Ref. -40 to 185°F (-40 to 85°C)
MR NUMBER	12

ACRYLIC TAPE AVAILABLE ON REQUEST

				BY	DATE	Title		
						ROUTER, OPTICAL FIBER		
						Part No.	03-79-138	
							03-80-45.	
							A	
A	Changed tape specs. to MR-59	9-21-20	FL	ALL ELECTRONICS HARDWARE INC. 2642 Corporate Parkway Algonquin, IL. 60102 1-800-778-7234		Drwg. type	CATALOG	9-21-20
No	Revision	Date	Init.			File No.	03-79-80	