

03-22 SERIES

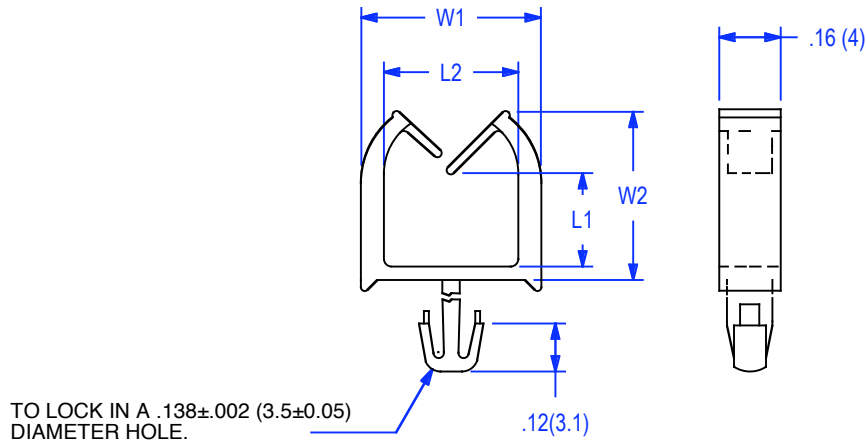

| .062 PANEL ITEM NO | .093 PANEL ITEM NO | L1 | L2 | W1 | W2 |
|-----------------------|-----------------------|-------------|-------------|--------------|--------------|
| | | 03-22-10 | 03-22-1-10 | .12 (3) | .26 (6.6) |
| 03-22-20 | 03-22-1-20 | .16 (4) | .32 (8.1) | .42 (10.8) | .36 (9.1) |
| 03-22-30 | 03-22-1-30 | .24 (6) | .36 (9.1) | .47 (12) | .44 (11.2) |
| 03-22-40 | 03-22-1-40 | .30 (7.7) | .36 (9.1) | .47 (12) | .51 (13) |

PACKAGING : 1000 PER BAG

| | |
|--------------------------|----------------------------|
| MATERIAL | NYLON 66 |
| UL RATING | 94V-2 |
| UL FILE NO. | E70062 |
| COLOR | NATURAL |
| ASTM | D 4066, PA111 |
| RoHS COMPLIANCE | YES |
| TEMPERATURE RANGE (REF.) | -40 to 185°F (-40 to 85°C) |
| MR NUMBER | 01 |

NYLON RATED UL94V-0 AVAILABLE ON REQUEST.
TO ORDER ADD SUFFIX "X" TO ITEM NUMBER.

| | | | | | | | | | |
|----|----------|------|------|-------------------------------------|--|------------------|--|----------|--|
| | | | | ALL ELECTRONICS HARDWARE , INC. | | Title | | Issue | |
| | | | | 2642 CORPORATE PARKWAY | | MINI CABLE GUIDE | | 0 | |
| | | | | ALGONQUIN, IL. 60102 1-800-778-7234 | | File No. | | Date | |
| No | Revision | Date | Init | | | 0322SERIES | | 12/01/08 | |