

01- 60 SERIES

HOLE DIAMETER = .125±.002 (3.18±0.05)
 PANEL THICKNESS = .062 (1.56)

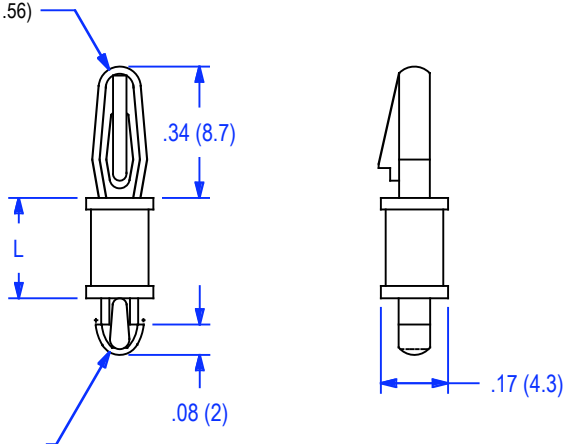

HOLE DIAMETER = .100±.002 (2.54±0.05)
 PANEL THICKNESS = .064 (1.63Max)

ITEM NO.	L	
	In. +/- .015	mm. ± 0.4
01-60-20	.125	3.2
01-60-30	.187	4.8
01-60-40	.250	6.4
01-60-50	.312	7.9
01-60-60	.375	9.5
01-60-70	.437	11.1
01-60-80	.500	12.7
01-60-90	.562	14.3
01-60-100	.625	15.9

PACKAGING : 1000 PER BAG.
 FOR V-0 RATED MATERIAL ADD SUFFIX "X"
 TO ITEM NUMBER.

MATERIAL	NYLON 66
UL RATING	94V-2
UL FILE NO.	E41938
COLOR	NATURAL
ASTM	D 4066, PA111
RoHS COMPLIANCE	YES
TEMPERATURE RANGE (REF.)	-40 to 185°F (-40 to 85°C)
MR NUMBER	12

				ALL ELECTRONICS HARDWARE , INC.	Title	PC SUPPORT	Issue	0
				2642 CORPORATE PARKWAY				
No	Revision	Date	Init	ALGONQUIN, IL. 60102 1-800-778-7234	File No.	0160series	Date	01/07/09