

01-51 SERIES

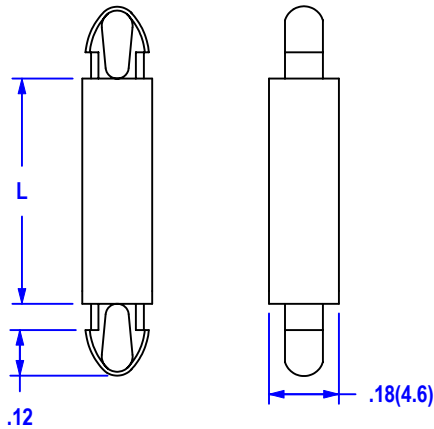

BOTH SIDES TO SNAP-LOCK IN A.138±.002 (3.5±0.05) DIA. HOLE
 .062 (1.5) PANEL THICKNESS.

| ITEM NO | DIM. L | |
|-----------|-----------------|-------------|
| | Inches ±.015 | mm ±0.38 |
| 01-51-20 | .078 | 2 |
| 01-51-30 | .118 | 3 |
| 01-51-40 | .156 | 4 |
| 01-51-50 | .197 | 5 |
| 01-51-60 | .236 | 6 |
| 01-51-70 | .276 | 7 |
| 01-51-80 | .314 | 8 |
| 01-51-100 | .394 | 10 |
| 01-51-120 | .472 | 12 |
| 01-51-140 | .551 | 14 |
| 01-51-160 | .630 | 16 |
| 01-51-180 | .709 | 18 |
| 01-51-200 | .787 | 20 |
| 01-51-220 | .866 | 22 |

| | |
|--------------------------|----------------------------|
| MATERIAL | NYLON 66 |
| UL RATING | 94V-2 |
| UL FILE NO. | E41938 |
| COLOR | NATURAL |
| ASTM | D 4066, PA111 |
| RoHS COMPLIANCE | YES |
| TEMPERATURE RANGE (REF.) | -40 to 185°F (-40 to 85°C) |
| MR NUMBER | 12 |

UL94V-0 NYLON AVAILABLE UPON REQUEST
 (ADD SUFFIX -X TO PART NUMBER)
 PACKAGING: 1000 PCS. PER BAG

| | | | | | | | | | |
|----|----------|------|----|--|--|--------------------------------------|--|----------------------|--|
| | | | | ALL ELECTRONICS HARDWARE , INC. | | Title MINIATURE PCB SUPPORTS. | | Issue A | |
| | | | | 2642 CORPORATE PARKWAY | | File No. 0151series | | Date 04/09/08 | |
| No | Revision | Date | By | ALGONQUIN, IL. 60102 1-800-778-7234 | | | | | |