

**01-16 SERIES**

TO SNAP IN A  $.125 \pm .002$  (3.18 $\pm$ 0.05) DIA. HOLE,  
 $.062$  (1.6) PANEL THICKNESS

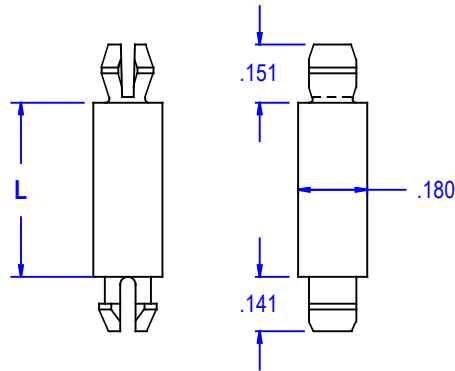

TO LOCK IN A  $.125 \pm .002$  (3.18 $\pm$ 0.05) DIA.  
HOLE,  $.062$  (1.6) PANEL THICKNESS

ITEM NO	L $\pm$ .015(0.38)	
	In.	mm
01-16-08	.080	2.00
01-16-10	.100	2.54
01-16-20	.125	3.18
01-16-30	.187	4.8
01-16-40	.250	6.35
01-16-50	.312	7.9
01-16-60	.375	9.6
01-16-70	.437	11.1
01-16-80	.500	12.7
01-16-90	.563	14.3
01-16-100	.625	15.9
01-16-110	.689	17.5
01-16-120	.750	19.1
01-16-130	.812	20.6
01-16-140	.875	22.2
01-16-150	.937	23.8
01-16-160	1.00	25.4
01-16-180	1.125	28.6
01-16-200	1.250	31.7
01-16-220	1.375	34.9
01-16-240	1.500	38.1

**PACKAGING : 1000 PER BAG**

MATERIAL	NYLON 66
UL RATING	94V-2
UL FILE NO.	E70062
COLOR	NATURAL
RoHS COMPLIANCE	YES
TEMPERATURE RANGE (REF.)	-40 to 185°F (-40 to 85°C)
MR NUMBER	15

				<b>ALL ELECTRONICS HARDWARE, INC.</b> 2642 CORPORATE PARKWAY ALGONQUIN, IL. 60102 1-800-778-7234	Title	Issue
A	Updated Item No. Table	6-11-20	FL		PCB SUPPORT, MINIATURE	A
No	Revision	Date	Init		File No. 01-16 series	Date 06/11/20