

**01-81 SERIES**

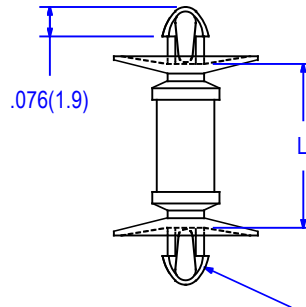

HOLE DIAMETER:  $.100 \pm .002$  (2.54 $\pm$ 0.05)  
 PANEL THICKNESS:  $.062$  (1.57).  
 BOTH ENDS.

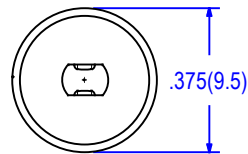

ITEM NO.	L	
	In. $\pm .015$	mm. $\pm 0.4$
01-81-30	.187	4.8
01-81-40	.250	6.4
01-81-50	.312	7.9
01-81-60	.375	9.5
01-81-70	.437	11.1
01-81-80	.500	12.7
01-81-90.	.562	14.3
01-81-100	.625	15.9

PACKAGING : 1000 PER BAG

UL 94V-0 MATERIAL AVAILABLE UPON REQUEST  
 TO ORDER ADD SUFFIX "X" TO ITEM NUMBER

MATERIAL	NYLON 66
UL RATING	94V-2
UL FILE NO.	E41938
COLOR	NATURAL
RoHS COMPLIANCE	YES
TEMPERATURE RANGE (REF.)	-40 to 185°F (-40 to 85°C)
MR NUMBER	12

					BY	DATE	Title MINI PCB SUPPORT DUAL LOCKING, CUPPED	
							Part No.	Issue
							01-81 SERIES	0
							Drwg. type	3-15-16
				FL			CATALOG	
No	Revision	Date	Init.				File No.	01-81 SERIES

ALL ELECTRONICS HARDWARE INC.  
 2642 Corporate Parkway  
 Algonquin, IL. 60102 1-800-778-7234