

01-05A SERIES

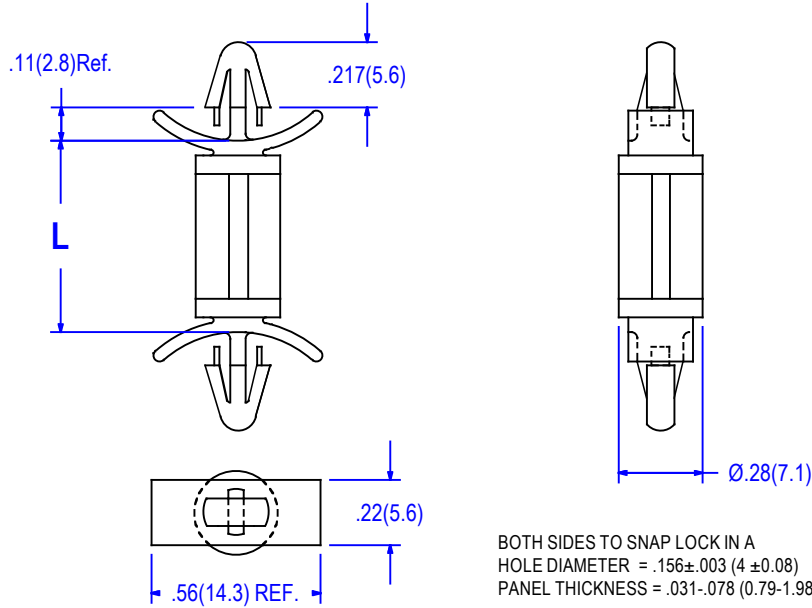

ITEM NO.	L	
	In. ±.015	mm. ± 0.4
01-05A-30	.187	4.8
01-05A-40	.250	6.4
01-05A-60	.375	9.5
01-05A-80	.500	12.7
01-05A-100	.625	15.9
01-05A-120	.750	19.1
01-05A-140	.875	22.2

PACKAGING : 1000 PER BAG

MATERIAL	NYLON 66
UL RATING	94V-2
UL FILE NO.	E41938
COLOR	NATURAL
ASTM	D 4066, PA111
RoHS COMPLIANCE	YES
TEMPERATURE RANGE (REF.)	-40 to 185°F (-40 to 85°C)
MR NUMBER	12

UL 94V-O MATERIAL AVAILABLE UPON REQUEST
TO ORDER ADD SUFFIX "X" TO ITEM NUMBER

				BY		DATE		Title PRINTED CIRCUIT BOARD SUPPORT, TWINN LOCK	
CUSTOMER APPROVAL									
VERIFIED								Part No. 01-05ASERIES	
REVIEWED				FL		.12-02-13			
DRAWN				FL		.12-02-13		Issue O	
DIMENSIONS				Inches (mm)		Tolerance .xx = ± .010 .xxx = .005			
				ALL ELECTRONICS HARDWARE INC. 2642 Corporate Parkway Algonquin, IL. 60102 1-800-778-7234				Drwg. type CATALOG	
No				Revision		Date		Init.	
								File No. 01-05Aseries	
								12-2-13	